

A WING WALL ELEVATIONS
S-2

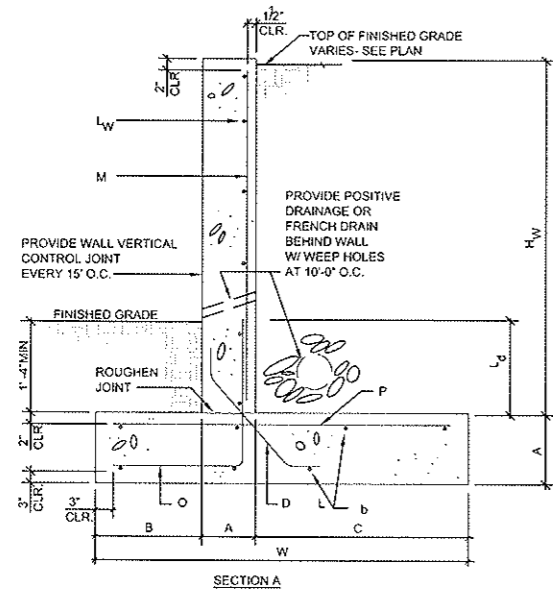

B TYPICAL RETAINING WALL SECTION A
CONC/WALL001

RETAINING WALL SCHEDULE												
Hw	CONCRETE DIMENSIONS				BASE REINFORCEMENT					STEM REINF.		BASE PRESS. (PSF)
	A	B	C	W	O	L _d	D	L _b	P	M	L _w	
3'-0"	8"	0'-6"	0'-11"	2'-1"	#4 AT 18"	1'-4"	#4 AT 18"	5#4	#4 AT 18"	#4 AT 18"	#4 AT 12"	1000
4'-0"	8"	0'-6"	1'-6"	2'-8"	#4 AT 18"	1'-4"	#4 AT 18"	5#4	#4 AT 18"	#4 AT 18"	#4 AT 12"	1250
5'-0"	8"	0'-6"	2'-1"	3'-3"	#4 AT 18"	1'-4"	#4 AT 18"	5#4	#4 AT 18"	#4 AT 18"	#4 AT 12"	1500
6'-0"	8"	0'-8"	2'-5"	3'-9"	#4 AT 18"	1'-4"	#4 AT 18"	6#4	#4 AT 18"	#4 AT 18"	#4 AT 12"	1600
7'-0"	8"	1'-0"	2'-6"	4'-2"	#4 AT 14"	1'-4"	#4 AT 14"	6#4	#4 AT 14"	#4 AT 14"	#4 AT 12"	1700
8'-0"	12"	1'-0"	2'-8"	4'-8"	#4 AT 14"	1'-4"	#4 AT 14"	7#4	#4 AT 14"	#4 AT 14"	#5 AT 12"	2000
9'-0"	12"	1'-0"	3'-2"	5'-2"	#5 AT 12"	1'-8"	#4 AT 12"	7#4	#4 AT 12"	#5 AT 12"	#5 AT 12"	2300
10'-0"	12"	1'-2"	3'-7"	5'-8"	#5 AT 12"	1'-8"	#4 AT 12"	8#4	#5 AT 12"	#5 AT 12"	#5 AT 12"	2450

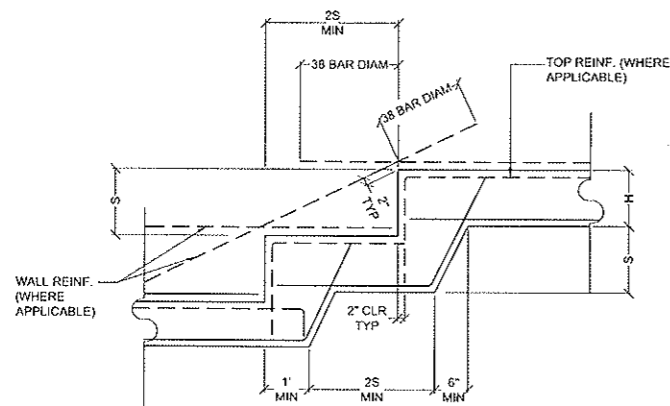

NOTE: S = 8" MINIMUM/2'-0" MAXIMUM

C TYPICAL STEPPED FOOTING DETAIL
S-2



HDR Engineering, Inc.
301 Perimeter Center North, Ste. 400
Atlanta, Georgia 30346
Phone: (678) 775-4800

Key Map

SOUTH PEACHTREE CREEK TRAIL - PHASE 2 PATH FOUNDATION

ISSUE	DATE	DESCRIPTION
PROJECT NUMBER	391092-83416	
PROJECT MANAGER	WRB	

PEDESTRIAN BRIDGE PLAN AND SECTION

SCALE	N/A
FILE NAME	83416-01-BRIDGE
SHEET NAME	S-2

